



Holland Permeare (80mm)

Holland Permeare

Holland Permeare is a permeable twist on a versatile classic. Its traditional rectangular brick shape can be used in historical and contemporary applications alike. Holland Permeare's 80mm thickness allows it to be used for heavy vehicular applications such as roadways and driveways.

Because rainwater infiltration is vital for the regeneration of groundwater and the health of vegetation, it is increasingly important that paving projects avoid sealing the earth. Permeable Pavers guarantee stability while allowing for penetration of rain and stormwater, relieving overburdened drain water systems and serving as an alternative to expensive sewer systems. With proper installation and maintenance, Permeable Pavers will not clog or seal off with dirt like porous concrete or asphalt pavements. Our wide range of Permeable Pavers suit any kind of project, be it residential or commercial.

Composition and Manufacture

Holland Permeare is made from a low moisture concrete mixture. It is made under high pressure and high frequency vibration, producing a very dense stone, low in water absorption (less than 5%) and high in compressive strength PSI (above 8000). It is designed to meet or exceed ASTM C-936 and ASTM C-67 (freeze/thaw) specifications.

Dimensions:

Thickness: **80mm** (3.149")

Width: **99.5mm** (3.917")

Length: **199.5mm** (9.37")

Pcs/SqFt: **4.56**

Approx Wt: **8.22 lbs/pc**

% Void: **9.11** (10mm gap)

Product Views:

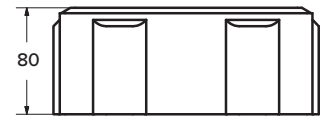
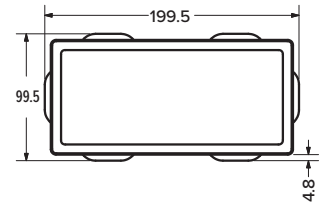
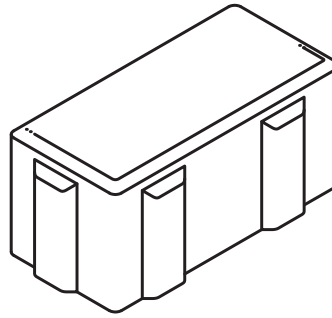

Pallet Layout:

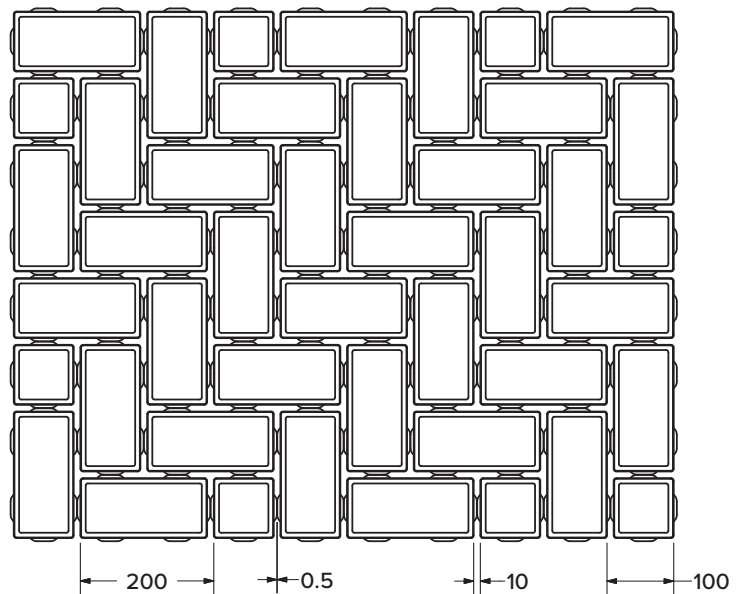

10095 Rickreall Rd. • Rickreall, OR 97371 | 9145 Fasset St. • Olympia, WA 98512

503.623.9084 | 360.878.9301

westerninterlock.com