

# Holland Permeare

## Holland Permeare

Holland Permeare combines a unique look that resembles the look of old European streets with water permeable joints. Holland Permeare is part of our popular paver family that includes Camino Stone and Roca Camino Stone. The traditional standard finish and the size compatibility with our Permeare Park gives this stone an exciting array of possibilities, sure to make it a popular product.

Rainwater infiltration is important for the regeneration of ground water and the health of vegetation. Water permeable pavement allows for this to happen, while providing a durable surface for vehicular traffic. Most importantly, a water permeable paving system will relieve overburdened drain water systems and serve as an alternative to expensive sewer systems.

Holland Permeare is part of our paver family that includes Holland Stone and Roca Holland Stone. These stones also module with our different Park & Plaza Stones, and work together to create a variety of projects.

## Composition and Manufacture

Holland Permeare is made from a low moisture concrete mixture. It is made under high pressure and high frequency vibration, producing a very dense stone, low in water absorption (less than 5%) and high in compressive strength PSI (above 8000). It is designed to meet or exceed ASTM C-936 and ASTM C-67 (freeze/thaw) specifications.

## Applications:

Western Interlock pavers may be used for:

- Parking Lots • Streets • Malls
- Heavy Industrial Areas

**“Enjoy the Durability, Beauty, Convenience and Value of The Perfect Paving System”**

## Dimensions:

Thickness: 60mm (2 3/8")

### Holland

Width: 98mm (3 7/8")

Length: 198mm (7 7/8")

Pcs/SqFt: 4.56

Approx Wt: 6 lbs/pc

### Park

Width: 198mm (7 7/8")

Length: 198mm (7 7/8")

Pcs/SqFt: 2.42

Approx Wt: 11 lbs/pc

## Product Views:

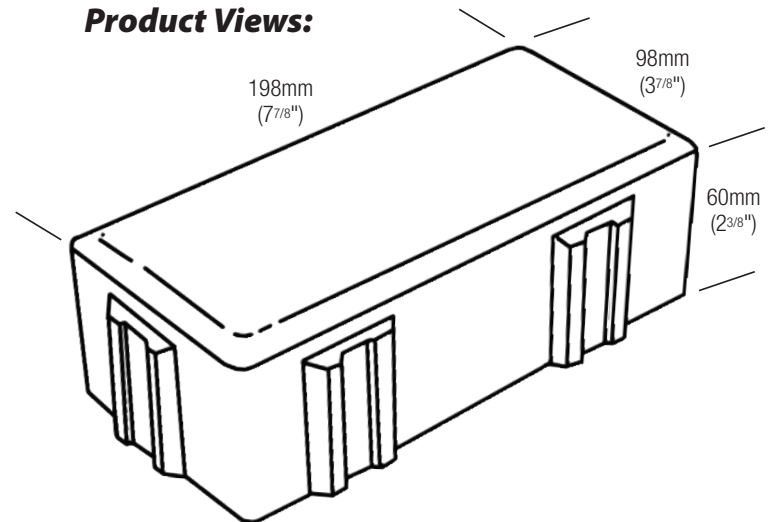

## Other Permeare products available to use with Holland Permeare

Park  
Permeare

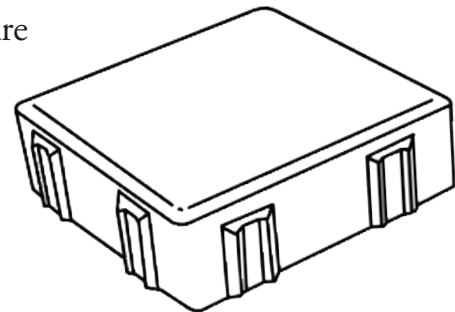

## Paving Stones and Retaining Wall Systems Made for the Northwest

Western Interlock, Inc.  
10095 Rickreall Rd.  
Rickreall, Oregon 97371

(503) 623-9084  
1 (800) 627-3153  
fax (503) 623-9122

Tumwater/Olympia 360-878-9301  
9145 Fassett St SW  
Olympia, WA 98512



# Holland Permeare Installation Instructions

*Note: Geotextile is optional depending on the soil conditions, and is placed on the compacted soil subgrade under the open graded base.*

Apply geotextile to the bottom and sides of the excavated area. Start laying geotextile at the top end of the drainage slope following down with overlapping joints of 24". Install all drain pipes, observation wells, overflow pipes in the base, depending on their location.

Place, grade and compact 2"-open aggregate for the sub base. The sub base is typically compacted to 6-8" lifts with a minimum 10-ton static roller. Make at least four passes per lift, with no visible movement in the sub base material when compaction is complete. Care must be taken to not damage the installed drain pipes during compaction and paving. Keep area where pavement is to be constructed free from sediment during entire job. Geotextile, base and bedding materials contaminated with sediment should be removed and replaced with clean materials.

After sub base is compacted, apply 4" of ¾-open aggregate for the base material. Compact with the same process as the sub base material. The base is typically compacted with a minimum 10-ton static roller. Make at least four passes with no visible movement in the base material when compaction is complete. The elevation of the compacted surface should not deviate more than  $\pm \frac{1}{2}$ " over the length of a 10' straightedge.

Screed 1-1½" of ¼-10 aggregate as a leveling course. Do not compact this layer!

Lay the paving stones on the leveling course in the patterns recommended by the manufacturer. Maintain straight pattern lines; use string lines if necessary. Cut pavers with a double bladed splitter or masonry saw to fill gaps at the edges of the paved area. Compact and seat the pavers into the bedding material by using a low amplitude (75-90 Hz) plate compactor capable of at least 5000 lbs centrifugal compaction force. During laying, all pavers within 3' of the laying face must be left fully compacted at the end of each day.

Sweep ¼-10 into the openings, vibrating and compacting the pavers again until the material is ½" from the top surface. This will require two or three passes with the compactor. Do not compact within 3" of the unrestrained edge of the paving stones. Remove excess aggregate by sweeping pavers clean.

The final surface elevations should not deviate more than  $\pm \frac{3}{8}$ " over the length of a 10' straightedge. The final surface elevations should be ⅛-¼" above adjacent drainage inlets, concrete collars or channels.

## Typical Cross Section of Holland Permeare Installation

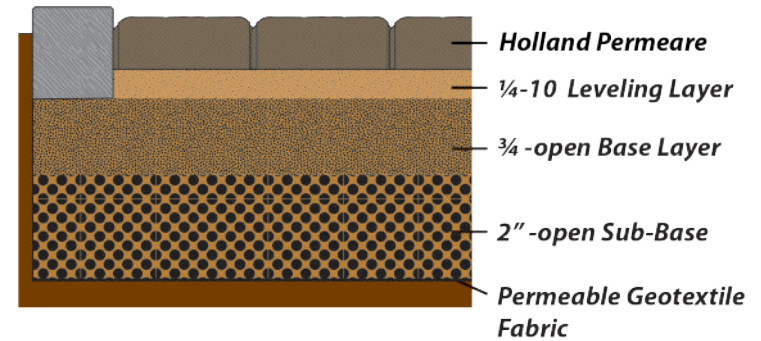

## Holland Permeare Installation Patterns

**Basketweave**

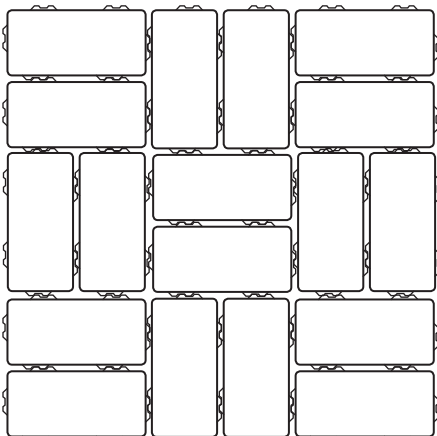

**Herringbone**

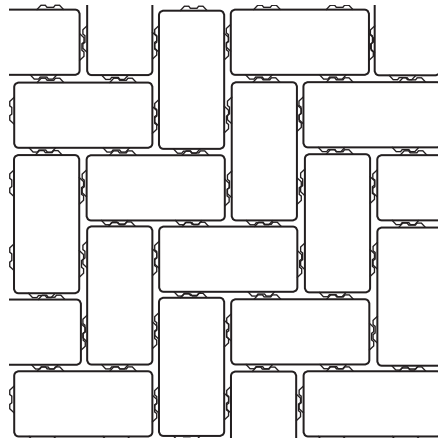

**Step Running Bond**

