

## I. EXCAVATION Figs. 1 & 2

Excavate 6" to 12" beyond the actual area to be covered by pavers, in this case a rectangular patio. The 6 to 12 inch "border area" allows for drainage and proper installation of Snap-Edge paver restraint edging. Excavation depth depends on your project and soil conditions. For a patio or walkway, a 2" base depth is OK assuming stable soil with good drainage. A depth of 4" or more may be required for poor soil or drainage areas.

The actual excavation depth is determined from the factors illustrated in Figure 1: base depth, paver thickness, sand depth, and desired finish level. Figure 2 shows the patio area after excavation. Locate points A, B, C & D with 3/8" dia. x 10" long nails. Check that  $AD = BC$  and  $BA = CD$  at the same time  $AC = DB$ . This insures a "true" rectangular patio that is perpendicular to your house. A string run from A to B to C to D can serve as a visual guide.

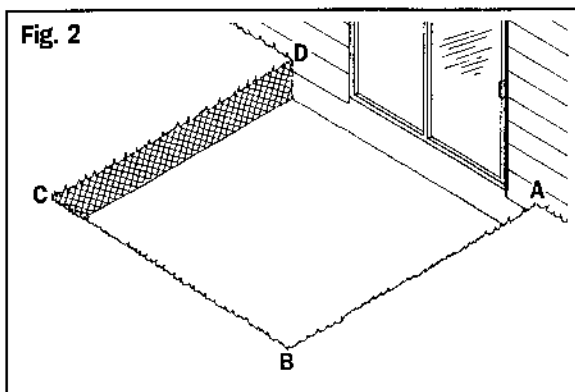
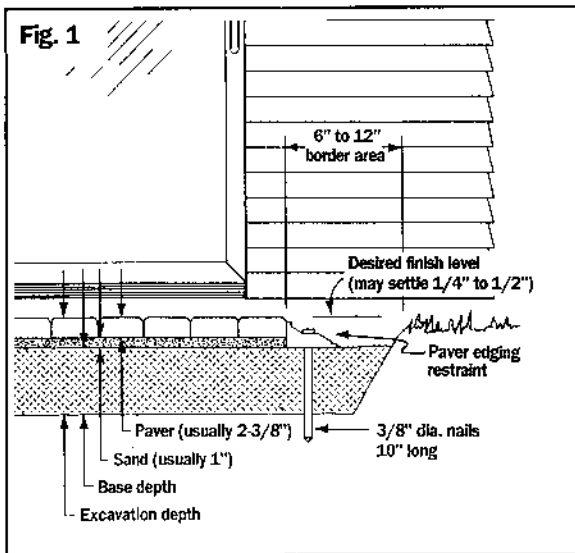

## II. BASE INSTALLATION Figs. 3, 4, 5, 6

A base consists of a layer of 3/4" crushed gravel material (including fines). Proper base installation consists of smoothing, compacting, leveling, and pitching. It is normal to repeat smoothing, compacting, leveling and pitching several times in order to obtain a good base. The leveling and pitching steps can also be used in the Excavation process in order to achieve a flat bottom surface.

### SMOOTHING Fig. 3

Drag a long straight 2 x 4 or 4 x 4 over the area until voids and high spots are corrected.

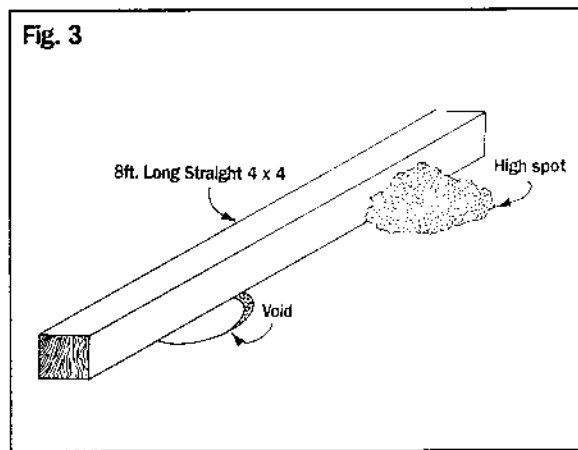

### COMPACTING Fig. 4

A rented vibrating gas powered plate compactor is passed over the entire base area. First, the compactor is used over the entire area with north/south passes; then east/west passes. The idea is to vary the pattern. After final compaction, check the entire area for proper pitch and level conditions.

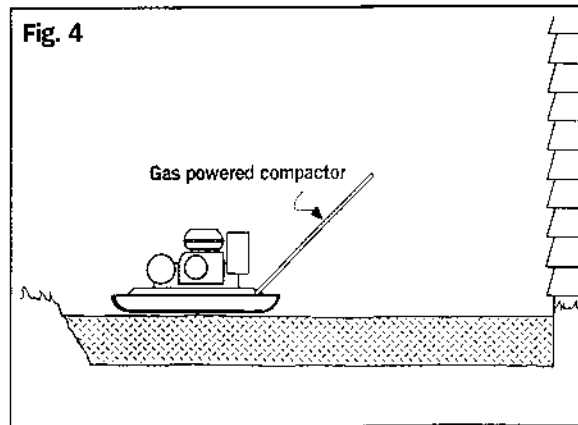

### LEVELING Fig. 5

A straight 2 x 4 and level are placed parallel to the house. Using the desired finish level as a guide, the base is checked to be sure it is level. Starting at the house, the level condition of the base is checked every 6" or so, until the entire area is complete. All checks are made with the 2 x 4 parallel to the house.

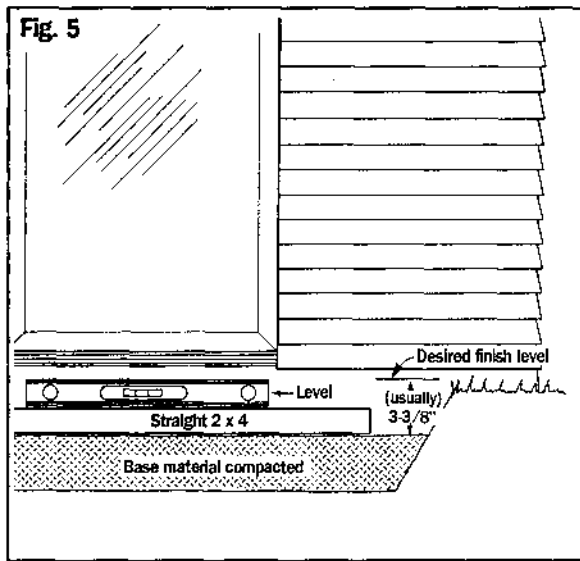

### PITCHING or SLOPING Fig. 6

A straight 2 x 4 and level placed perpendicular to the house is used to check base pitch or slope. A 5/8" gap (Fig. 6) for ten feet may be enough. Your circumstances may dictate more or less. Check the pitch or slope in this way every 6" or so, until the entire area is complete. This helps rain water drain away from the house. As illustrated in Figure 6, 1/16 inch pitch per foot of 2 x 4 is enough pitch for average circumstances.

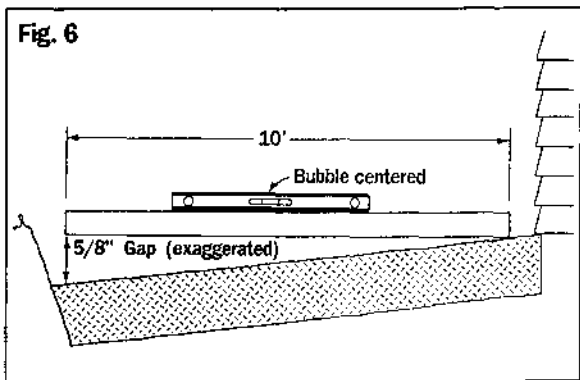

### III. EDGING INSTALLATION Figs. 7 & 8

Install edging restraint 6" to 12" from the edge of the base using 3/8" dia. x 10" long nails (also called spikes). Nails are spaced about 12 to 24 inches apart for average conditions. The joints between sections of edging should be planned so they do not occur in sharp corners. The end treatments shown in Fig. 7 (at corners D and A) offer two different ways for the edging to terminate against the house. Treatment D offers more security than A, but requires a few extra nails. Remember, bend the edging around corners by cutting away nail-hole bosses and snipping supports, as required.

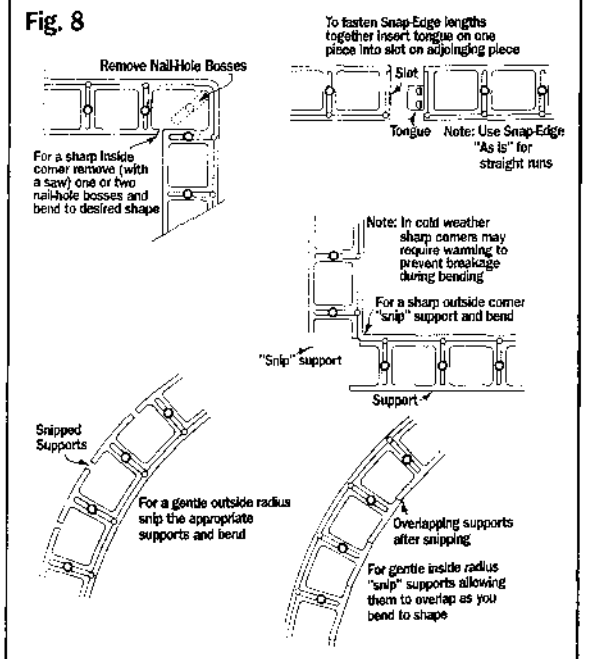
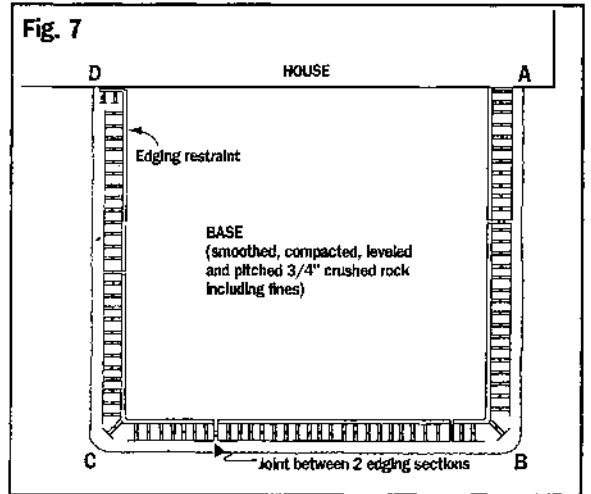

## IV. SCREEDING SAND/ LAYING PAVERS Figs. 9 & 10

Screed coarse, dry sand (Fig. 9 & 10) using 1" diameter electrical conduit pipes as screed rails. Screed a section 8' to 10' in length. Once you have started screeding sand, the project should be covered if rain is anticipated. Rain will "wash out" the project. Remember, you must fill in the voids caused by the screed rails. Make sure you can reach the void areas without walking on the smooth screeded sand. You can do this by gently walking over the pavers as they are placed on the sand.

Select the paver pattern of your choice (ask your supplier). Lay the pavers gently on the sand, but be sure to place each paver firmly against its neighbors. Start laying the pavers from the house out. Complete the laying process with whole pavers only. Alternate between screeding sand and laying pavers until the entire project is complete. As you lay the pavers, make sure the seams are true and square from row to row; or row to every other row (depending on the pattern you have selected).

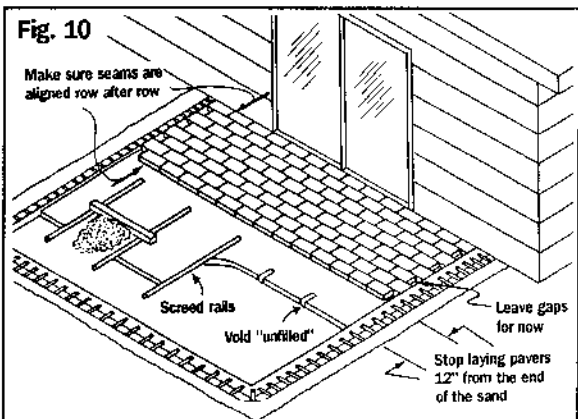
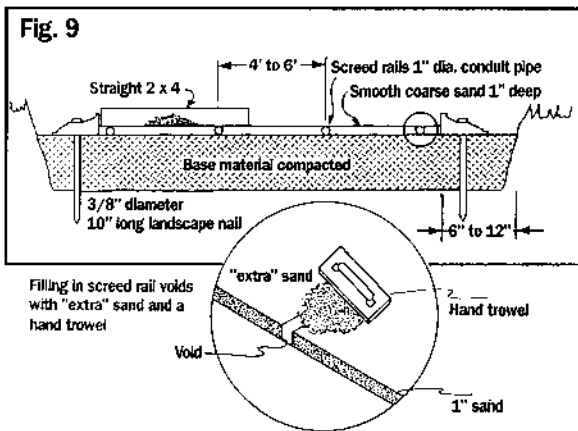

## V. FINISHING THE PROJECT Fig. 11

Using a rented Mason diamond saw or a block splitter (you must follow manufacturers instructions when using these items), cut the paver pieces required and fill in all gaps in the project.

Sweep the entire project clean. Using a plate compactor make repeated passes in multiple directions over the entire area. Start compacting around the outermost boundary.

When compacting is completed, (ie: the pavers are level and flat) use a broom to spread dry, coarse sand into the joints between pavers. Do so until the joints are filled with sand. Alternate compacting, and "brooming" sand into the joints until the joints no longer "open up" during compacting. Pavers may settle 1/4" to 1/2" during compacting. Figure 11 shows four steps in one view. In reality these steps are performed sequentially, not all at one time. Backfill project as soon as possible.

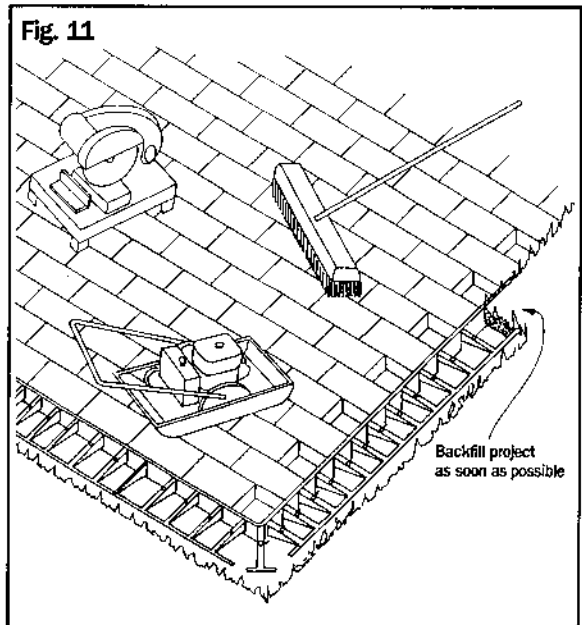

## VI. FINALLY

The preceding instructions outline how to install a paving stone patio. The patio described is pitched in a perpendicular direction away from the house for rain water run-off.

Other paving stone projects may require deviation from these instructions and are beyond the scope of this pamphlet. For example, if your project follows rolling contours or is "crowned" (like the center of a highway), plastic pipe screed rails will better conform to your topography.

Good safety practices must be followed including safety goggles, safety gloves, steel toed shoes, knee guards, and protective clothing. Also, the operating instructions should be followed for all rented equipment. This is very important.

Mason diamond saws and plate compactors can be dangerous to operate without proper instruction. Trying to split pavers with a hammer/chisel or block splitter can result in eye loss: Use safety goggles. Obtain proper instructions, your paving stone supplier may be able to offer advice.

---

### **About the Cover...**

*Sweeping designs flowing from patio to driveway can be accomplished with a little extra advice from your paver supplier. (See cover). Snap-Edge paver restraint is used around trees and to form planters. Snap-Edge holds down landscape fabric so weeds won't grow in planter areas — sprinkler heads are easily installed close to the pavers without cutting Snap-Edge. Your paving stone supplier knows local conditions and practices — he can advise you. For example: driveways may require 6" or more of base materials: nail spacing depends, to some degree, on your soil conditions.*

*Paver projects are easy to do — but they do require time.*

---

Your paving stone supplier is:

# INSTALLING YOUR OWN PAVING STONE PATIO

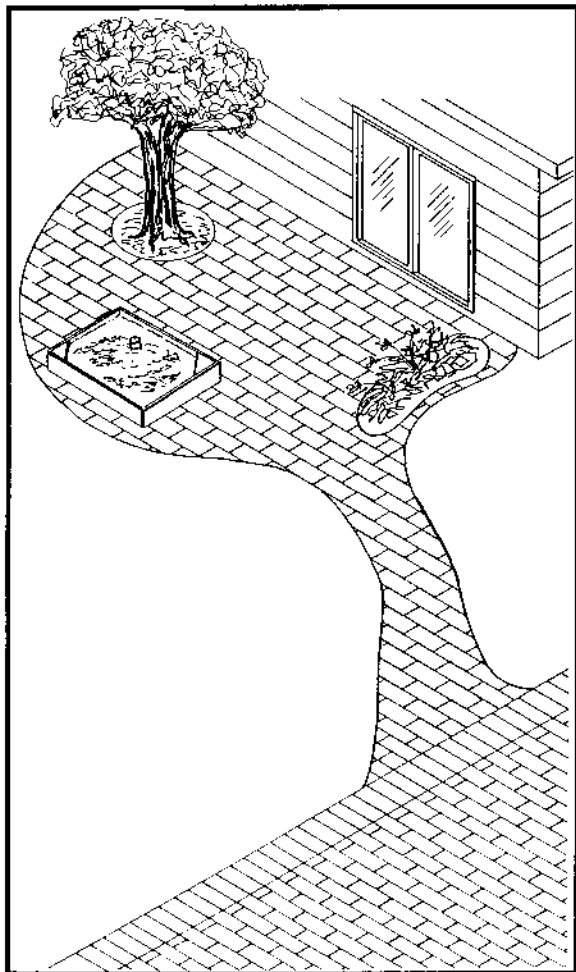

**SNAP**  
**EDGE**  
CORPORATION